

Document Number		RG-SPEC-IGN 1A	
Title		IGN1A Ignition Coil (P/N: M IGN1A)	
Revision	Date	Prepared By	Change History
1	8/26/2014	JW	Initial release

Introduction:

The RaceGrade IGN1A coil is an inductive 'smart coil' capable of producing extremely high spark energy (103mJ +) making it ideal for many high horsepower applications. The coil-near-plug form factor allows it to be remotely mounted away from the cylinder head to promote lower operating temperatures of the coil, improving longevity and performance. The IGN1A is ideally suited for a wide variety of applications, ranging from moderate powered endurance applications through 3000+ horsepower blown alcohol motors. It is the ideal combination of high spark energy and long spark duration.

Field proven for exceptional reliability and performance, the IGN1A's built-in igniter allows for a simplified installation and is ideal for use with all MoTeC ECU's (and most other brands). No external igniter or CDI is required for these coil to function.

When installing the IGN1A, special attention must be paid to the quality of the connections due to the immense energy of this coil. The center pin (Terminal C) **MUST** be grounded to the cylinder head. *The coil will not supply full power if it is not grounded to the cylinder head.* Please refer to the Characteristic Dwell Time chart listed below. The coil will overheat if operated at excessive duty cycles for prolonged periods. Do not operate this coil at a duty cycle greater than 40%.

Part# M IGN1A

Connection:

- A: Coil Trigger (ECU Trigger)
- B: Coil Trigger (ECU 0V)
- C: GND to Cyl Head
- D: Battery GND
- E: Battery POS

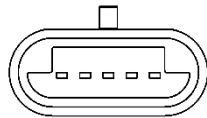

A B C D E
*WIRE ENTRY VIEW

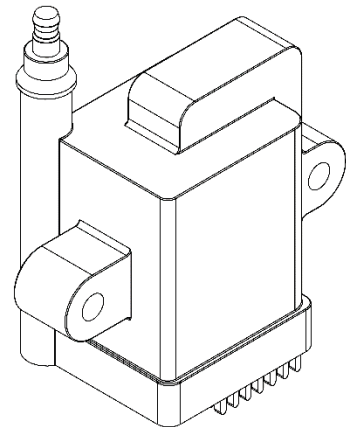

Mating Connector: M 12-2825 (included)

Note: The connector is a 'pull to seat' connector. The wires must be fed through the connector before termination.

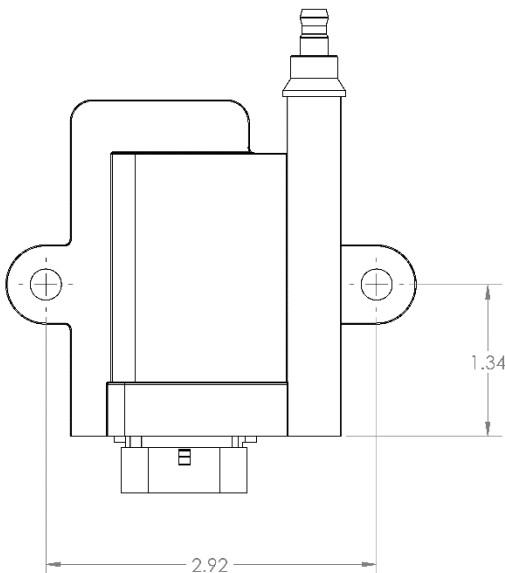

*Dimensions in inches

Characteristic Dwell Time (ms)

<i>I</i> _{Primary}	<i>V</i> _{Battery}						
	6 V	8 V	10 V	12 V	14 V	16 V	18 V
4 A	6.7	4.6	3.4	2.7	2.3	1.9	1.6
6 A	12.4	7.7	5.6	4.3	3.6	3	2.6
8 A	22	10.8	7.5	5.8	4.8	3.9	3.5
10 A		13.5	8.9	6.7	5.5	4.6	3.9
12 A			10.3	7.4	5.9	4.9	4.3
14 A				8.4	6.4	5.3	4.5
16 A						5.8	4.9

Characteristic Dwell Time is a function of battery voltage and primary current. For maximum spark energy, please use the maximum listed dwell time at operating battery voltage. The needed dwell time should be verified with a current measurement device.